

## FrSky 2.4GHz ACCST X4R / X4RSB Manual

### Introduction

Thank you for purchasing FrSky X4R 4ch(X4RSB,3/16ch) full duplex telemetry receiver. In order to fully enjoy the benefits of this system, please read the instruction manual carefully and set up the device as described below.

### Overview

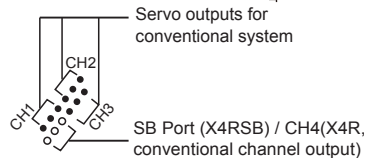
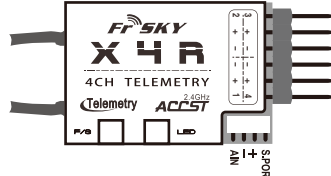
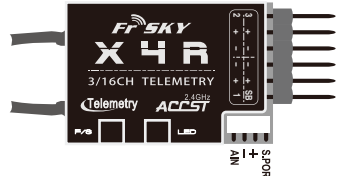

| Green LED   | RED LED  | Status       |
|-------------|----------|--------------|
| ON          | Flashing | Binding      |
| Flashing    | OFF      | Normal       |
| OFF         | Flashing | Signal Lost  |
| Flash Twice | Off      | Failsafe Set |

### Specifications

Dimension: 40×22.5×6mm (L × W × H)

Weight: 5.8g

Number of Channels:

- X4R-4ch from conventional channel outputs, without SBUS port
- X4RSB-3/16ch (1~3ch from conventional channel outputs, 1~16ch from SBUS channel)

Operating Voltage Range: 4.0~10V

Operating Current: 100mA@5V

Operating Range: full range (>1.5km)

With RSSI output on board: PWM voltage output (0~3.3V)

Firmware Upgradeable

Compatibility: FrSky X-series Module (XJT etc. ) & Taranis X9D in D16 mode  
(X4R / X4RSB is not work with D-series Module)



### Features

- Smart Port enabled
- With external Analog Telemetry port (AD2)
- Lighter weight and physically smaller than X8R and X6R
- With RSSI PWM output (0~3.3V) on board



Smart Port (S. Port) is a signal wire full duplex digital transmission interface developed by FrSky Electronic Co., Ltd. All products enabled with Smart Port (including XJT module, X4R, X6R and X8R receiver, new hub-less sensors, new Smart Dashboard, etc), serial port user data and other user input / output devices can be connected without limitations for numbers or sequences at a high transmission speed.

### Binding Procedure

Binding is the process of uniquely associating a particular receiver to a transmitter module. A transmitter module can be bound to multiple receivers (not to be used simultaneously). A receiver can only be bound to one transmitter module.

Follow the steps below to finish the binding procedure.

- Turn on the transmitter while holding the F/S button on the module (please refer to the module instruction manual for switch positions). Release the button. The RED LED on the module will flash, indicating the transmitter is ready to bind to the receiver.
- Connect battery to the X4R receiver while holding the F/S button on the receiver. The LED on the receiver will flash, indicating the binding process is completed.
- Turn off both the transmitter and the receiver.
- Turn on the transmitter and connect the battery. The GREEN LED on the receiver indicates the receiver is receiving commands from the transmitter. The receiver / transmitter module binding will not have to be repeated, unless one of the two is replaced.

**Note: After binding procedure is completed, recycle the power and check if the receiver is really under control by linked transmitter.**

### Range Check

A pre-flight range check should be done before each flying session. Reflections from nearby metal fences, concrete buildings or trees can cause loss of signal both during range check and during the flight. Follow the steps below to perform the range check.

- Place the model at least 60cm (two feet) above non-metal contaminated ground (e.g. on a wooden bench).
- The receiver antennas should be separated in the model, and do not touch the ground.
- The module antenna should be in a vertical position.
- Turn on the transmitter and the receiver, press the F/S button on the XJT module for 4 seconds to enter range check mode, the RED LED will be off, GREEN LED will flash rapidly. The effective distance will be decreased to 1/30 (at least 30m).
- Walk away from the model while simultaneously operating the controls on the transmitter to confirm all controls' normal operation.
- Press the F/S button on the XJT module for 1~2 seconds to exit range check mode, RED LED will be back on, indicating normal operation is back.

### Failsafe

Failsafe is a useful feature in which all controls move to a preset position whenever the control signal is lost for a period of time. X4R supports failsafe function for all channels. Follow the steps below to set failsafe positions for each channel:

- Bind the receiver first and turn on both the transmitter and the receiver;
- Move the controls to the desired failsafe position for all channels;
- Press briefly the F/S button on the receiver (less than 1 second). The Green LED will flash twice, indicating the failsafe position has been set in the receiver.

To disable the failsafe function, re-bind the receiver.

Failsafe is recommended to set when system is firstly used, or receiver has been re-bound. Follow steps below to set failsafe.

Option-1. How to set failsafe to a user-determined state on lost signal:

- Bind the receiver to the transmitter module first and turn on both the transmitter and the receiver;
- Move the controls to desired failsafe position for all channels;
- Press briefly the F/S button on the receiver and you are done.

Option-2. How to set failsafe for no pulses on lost signal:

- Turn off the transmitter, power on the receiver, and then press briefly the F/S button on the receiver.

**Note: If failsafe is not set, failsafe default will hold last position before signal is lost. In this case, there exists risk that your model will fly away or cause injury.**

For more details, please check the complete manual for X4R from [www.frsky-rc.com](http://www.frsky-rc.com) - Download -Manual. Should you have other questions, please send e-mails to FrSky technical support [sales4tech@gmail.com](mailto:sales4tech@gmail.com).

## FrSky 2.4GHz ACCST X4R / X4RSB Manual

### How to connect Smart Port enabled sensors and/or FBVS-01 to X4R/X4RSB

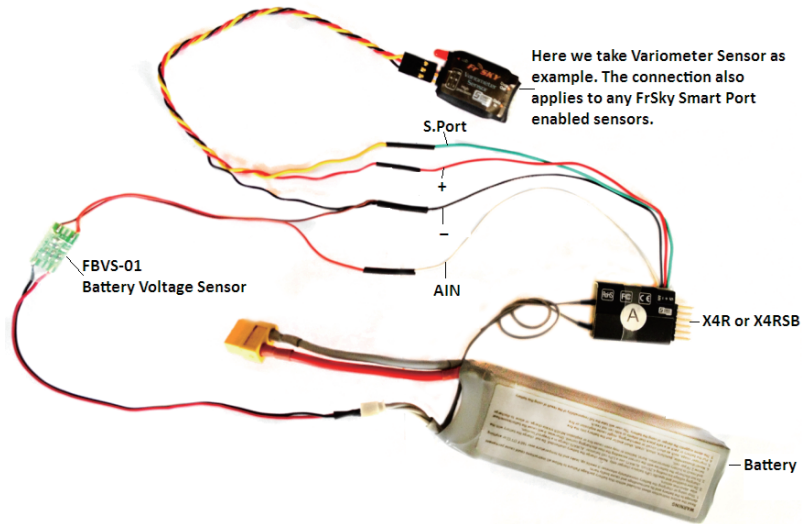

Smart Port enabled sensors and X4R/X4RSB

| Smart Port Cable |     | X4R/X4RSB Cable |
|------------------|-----|-----------------|
| Yellow           | <=> | Green/Yellow    |
| Red              | <=> | Red             |
| Black            | <=> | Black           |

FBVS-01 and X4R/X4RSB

| FBVS-01 |     | X4R/X4RSB Cable |
|---------|-----|-----------------|
| Red     | <=> | White           |
| Black   | <=> | Black           |

**Note: refer to the above picture and charts for the correct connection. Use the heat shrink tube on the exposed wires to prevent accidental in-flight short circuit.**